

プッシュリベット

Pシリーズ



特長

- ビス等にかわるパネル固定具です。
- 指先でピンを押し込むことで、脚部が押し広げられパネルを固定します。

材質 ナイロン6 UL94V-2

標準色 白・黒

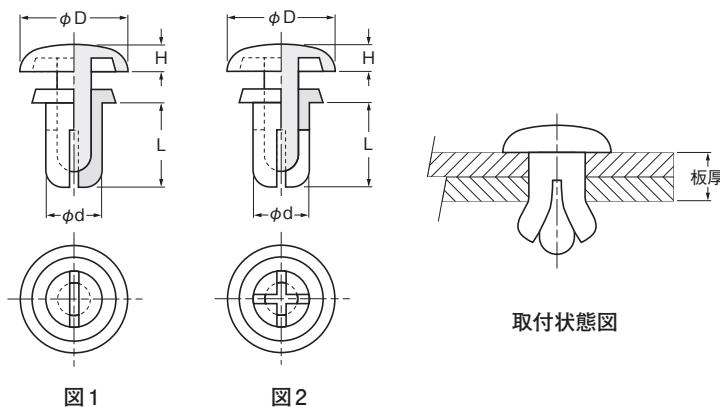

品番	寸法 (mm)						図	抜去力 N (kgf) 以上	包装単位 (個)
	取付穴	適用板厚	φ D	H	φ d	L			
P2024	2.1	0.6~1.2	4.2	1.2	2.0	2.4	1	29.4 (3)	1,000
P2032	2.1	1.3~2.0	4.2	1.2	2.0	3.2		29.4 (3)	
P2040	2.1	2.1~2.8	4.2	1.2	2.0	4.0		29.4 (3)	
P2048	2.1	2.9~3.6	4.2	1.2	2.0	4.8		29.4 (3)	
P2064	2.1	3.7~4.4	4.2	1.2	2.0	6.4		29.4 (3)	
P2632	2.7	1.0~2.0	5.0	1.4	2.6	3.2		49 (5)	
P2642	2.7	2.1~3.0	5.0	1.4	2.6	4.2		49 (5)	
P2648	2.7	2.7~3.6	5.0	1.4	2.6	4.8		49 (5)	
P2655	2.7	3.4~4.3	5.0	1.4	2.6	5.5		49 (5)	
P3035	3.1	1.0~2.0	6.4	1.6	3.0	3.5		78.4 (8)	
P3045	3.1	2.0~3.0	6.4	1.6	3.0	4.5		78.4 (8)	
P3055	3.1	3.0~4.0	6.4	1.6	3.0	5.5		78.4 (8)	
P3065	3.1	4.0~5.0	6.4	1.6	3.0	6.5		78.4 (8)	
P3075	3.1	5.0~6.0	6.4	1.6	3.0	7.5		78.4 (8)	
P3080	3.1	5.5~6.5	6.4	1.6	3.0	8.0		78.4 (8)	
P3090	3.1	6.5~7.5	6.4	1.6	3.0	9.0	78.4 (8)		
P3100	3.1	7.5~8.5	6.4	1.6	3.0	10.0	78.4 (8)		
P3535	3.6	1.2~2.1	6.4	1.6	3.5	3.5	2	117.6 (12)	
P3545	3.6	2.2~3.1	6.4	1.6	3.5	4.5		117.6 (12)	
P3550	3.6	2.7~3.6	6.4	1.6	3.5	5.0		117.6 (12)	
P3555	3.6	3.2~4.1	6.4	1.6	3.5	5.5		117.6 (12)	
P3560	3.6	3.7~4.6	6.4	1.6	3.5	6.0		117.6 (12)	
P3570	3.6	4.7~5.6	6.4	1.6	3.5	7.0		117.6 (12)	
P4040	4.1	1.4~2.4	8.0	1.8	4.0	4.0		196 (20)	
P4050	4.1	2.5~3.5	8.0	1.8	4.0	5.0		196 (20)	
P4060	4.1	3.5~4.5	8.0	1.8	4.0	6.0		196 (20)	
P4070	4.1	4.5~5.5	8.0	1.8	4.0	7.0		196 (20)	
P4080	4.1	5.5~6.5	8.0	1.8	4.0	8.0		196 (20)	
P4090	4.1	6.5~7.5	8.0	1.8	4.0	9.0		196 (20)	
P4100	4.1	7.5~8.5	8.0	1.8	4.0	10.0		196 (20)	
P4120	4.1	9.5~10.5	8.0	1.8	4.0	12.0		196 (20)	
P5045	5.1	1.5~2.5	9.0	2.2	5.0	4.5		245 (25)	
P5055	5.1	2.5~3.5	9.0	2.2	5.0	5.5	245 (25)		
P5065	5.1	3.5~4.5	9.0	2.2	5.0	6.5	245 (25)		
P5075	5.1	4.5~5.5	9.0	2.2	5.0	7.5	245 (25)		
P5085	5.1	5.5~6.5	9.0	2.2	5.0	8.5	245 (25)		
P5095	5.1	6.5~7.5	9.0	2.2	5.0	9.5	245 (25)		
P5105	5.1	7.5~8.5	9.0	2.2	5.0	10.5	245 (25)		
P6060	6.1	2.5~4.0	12.0	2.5	6.0	6.0	294 (30)		
P6080	6.1	4.0~5.5	12.0	3.0	6.0	8.0	294 (30)		

掲載の製品以外にも各種あります。詳細はお問い合わせください。

光洋ファスナー(株) 製品

ディップ製品

端子用絶縁スリーブ

基板アクセサリ

配線クランプ

配線保護材

EMC対策品

ファスナー／標示品／フェールキャップ