

WIRING ACCESSORY



SHINAGAWA SHOKO FASTENER

● Push fastener	F series	86
● Push rivet	P series	87
● Case leg	FF series	88

Push fastener

F series



Feature

- New kind of fixation fitting replacing screws.
- Can be used for mounting PC boards, plates etc.
- Easy to mount with single-push owing to one-piece structure.

Material

Nylon 66 UL94V-2

Standard color

Black

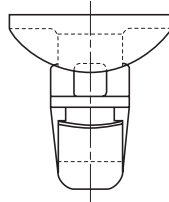
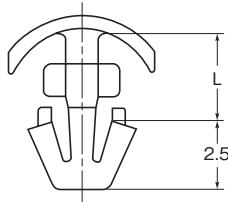
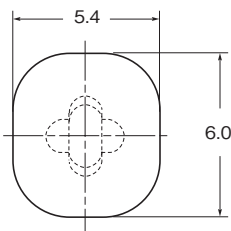
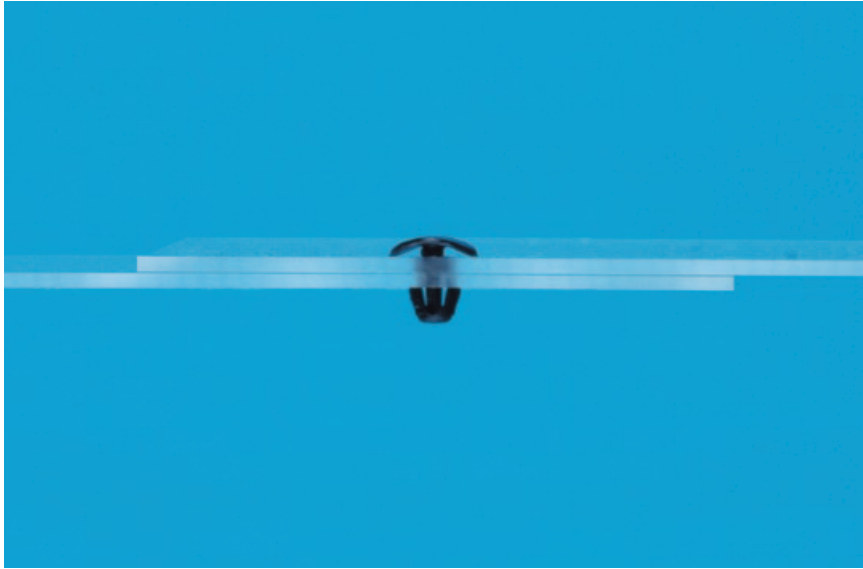

Mounted

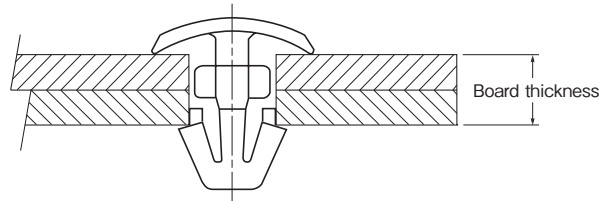

Part No.	Dimensions (mm)			Insertion force N (kgf)	Extraction force N (kgf)	Packing unit (pieces)
	L	Mounting hole	Applicable board thickness			
F32025	2.9	φ 3.0	2.0 ~ 2.5	14.7 ~ 24.5 (1.5 ~ 2.5)	88.2 (9) or more	500
F32530	3.4		2.5 ~ 3.0			

Push rivet

P series



Feature

- New kind of fixation fitting replacing screws.
- Push the pin in to spread the rivet leg to secure the panel.

Material

Nylon 6 UL94V-2

Standard color

White, Black

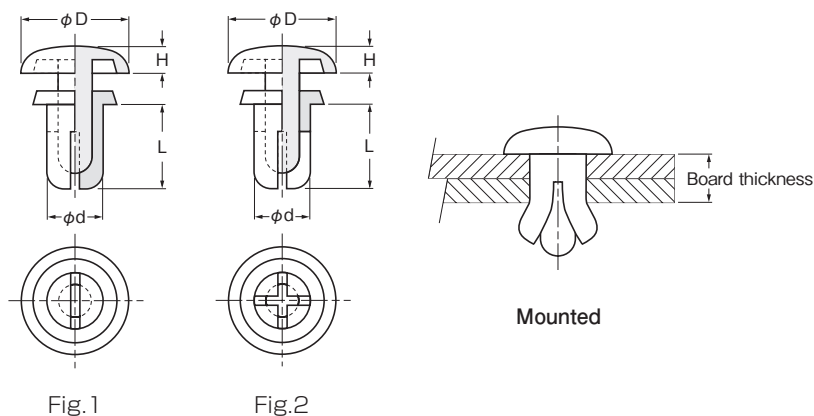

Fig.1

Fig.2

Part No.	Dimensions (mm)						Fig.	Extraction force N (kgf)	Packing unit (pieces)
	Mounting hole	Applicable board thickness	ϕD	H	ϕd	L			
P2024	2.1	0.6 ~ 1.2	4.2	1.2	2.0	2.4	29.4 (3)	1,000	
P2032		1.3 ~ 2.0				3.2			
P2040		2.1 ~ 2.8				4.0			
P2048		2.9 ~ 3.6				4.8			
P2064		3.7 ~ 4.4				6.4			
P2632	2.7	1.0 ~ 2.0	5.0	1.4	2.6	3.2	49 (5)	1,000	
P2642		2.1 ~ 3.0				4.2			
P2648		2.7 ~ 3.6				4.8			
P2655		3.4 ~ 4.3				5.5			
P3035	3.1	1.0 ~ 2.0	6.4	1.6	3.0	3.5	78.4 (8)	1,000	
P3045		2.0 ~ 3.0				4.5			
P3055		3.0 ~ 4.0				5.5			
P3065		4.0 ~ 5.0				6.5			
P3075		5.0 ~ 6.0				7.5			
P3080		5.5 ~ 6.5				8.0			
P3090		6.5 ~ 7.5				9.0			
P3100	7.5 ~ 8.5	10.0							
P3535	3.6	1.2 ~ 2.1	6.4	1.6	3.5	3.5	117.6 (12)	1,000	
P3545		2.2 ~ 3.1				4.5			
P3550		2.7 ~ 3.6				5.0			
P3555		3.2 ~ 4.1				5.5			
P3560		3.7 ~ 4.6				6.0			
P3570		4.7 ~ 5.6				7.0			
P3580	5.7 ~ 6.6	8.0							
P4050	4.1	2.5 ~ 3.5	8.0	1.8	4.0	5.0	196 (20)	1,000	
P4060		3.5 ~ 4.5				6.0			
P4070		4.5 ~ 5.5				7.0			
P4080		5.5 ~ 6.5				8.0			
P4090		6.5 ~ 7.5				9.0			
P4100	7.5 ~ 8.5	10.0							
P5045	5.1	1.5 ~ 2.5	9.0	2.2	5.0	4.5	245 (25)	1,000	
P5055		2.5 ~ 3.5				5.5			
P5065		3.5 ~ 4.5				6.5			
P5075		4.5 ~ 5.5				7.5			
P5085		5.5 ~ 6.5				8.5			
P5095		6.5 ~ 7.5				9.5			
P5105	7.5 ~ 8.5	10.5							
P6060	6.1	2.5 ~ 4.0	12.0	2.5	6.0	6.0	294 (30)	1,000	
P6080		4.5 ~ 5.5		3.0					8.0

Not all product are listed here. Please contact us for details.

Case leg

FF series



Feature

- Easy to mount by only pushing the pin in.

Applications

- Leg of desktop devices etc.

Material

Body: Elastomer UL94V-2, 94HB
 Rivet: Nylon 6 UL94V-2
 Screw pin: Polyacetate UL94HB

Standard color

Black

Fig.1

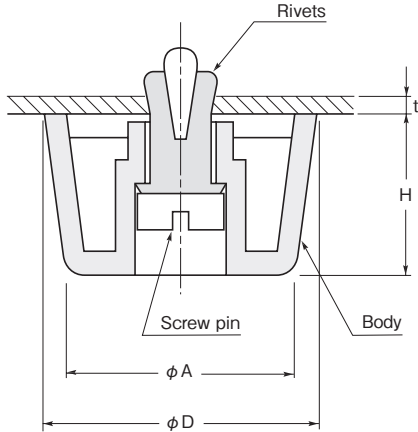
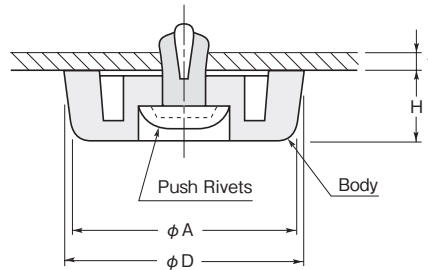

Fig.2



Part No.	Dimensions (mm)										Extraction force N (kgf)	Fig.	Packing unit (pieces)	
	φ A	φ D	H	Mounting hole	Screw pin	Applicable board thickness								
						At mounted								
P3055	P4050	P4060	P4070	P4080	P5065									
FF001-AR79	20.0	24.0	14.0	φ 5.0	1.0 ~ 2.3							294 or more (30)	1	200
FF004-AR79	18.0	20.0	10.0	φ 5.0	1.0 ~ 2.3									
FF015-AR79	28.0	30.0	15.0	φ 5.0	0.8 ~ 2.0									
FF003-AR79	13.5	14.2	5.5	φ 3.1		0.8 ~ 1.8						78 or more (7.9)	2	500
FF005-AR79	20.0	21.0	4.2	φ 4.1			0.8 ~ 1.8	1.8 ~ 2.8	2.9 ~ 3.7	3.8 ~ 4.8		147 or more (15)		
FF006-AR79	14.0	15.0	6.0	φ 4.1				0.6 ~ 1.0	1.0 ~ 2.0			294 or more (30)		
				φ 5.1							0.8 ~ 1.2			
FF008-AR79	20.0	21.0	6.0	φ 4.1			0.8 ~ 1.8	1.9 ~ 2.8	2.9 ~ 4.0			147 or more (15)		
FF009-AR79	20.0	21.0	8.0	φ 4.1				1.5 ~ 2.5	2.1 ~ 3.0				200	
FF010-AR79	14.0	15.0	9.0	φ 4.1				0.6 ~ 1.0	1.0 ~ 2.0			294 or more (30)	500	
				φ 5.1							0.8 ~ 1.2			
FF013-AR79	10.0	10.8	4.0	φ 3.6				P3545 0.6 ~ 1.0	P3555 1.0 ~ 2.0			98 or more (10)	100	

Not all product are listed here. Please contact us for details.